



# Cirque® Series COMMERCIAL RECEPTACLES

Round architectural landscape container with 24 vertical facets, and clear powder-coated spun aluminum lid.



## TO SPECIFY

Select the CS product number along with the options below.

### Concrete Color

- Natural gray concrete
- Choose integral pigment color from Davis Colors, call/email us for a Davis Colors selector brochure
- Custom color mixing available

### Finishing

- Sandblast finish

### Lids

- Model CS-TR is a trash only lid
- Model CS-TRA is a trash lid with an ash disposal channel

### Notes

- A 32-gallon heavy-duty plastic waste can is included
- Metal components fitted with security chains
- Matching Cirque Landscape Containers
- Contact us for CSI specifications

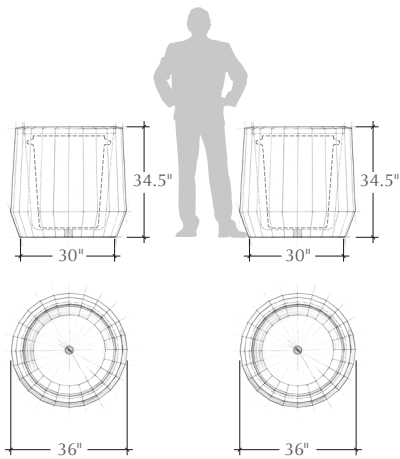

CS-TR  
1285 lb.

CS-TRA  
1285 lb.



Trash Only Lid



Trash & Ash Lid

All weights are approximate

In 2017©, Larry Kornegay designed the Cirque® Series exclusively for Kornegay Design, LLC | Patent D779,372